

INSTALLATION INSTRUCTIONS

Additional Instructions for Wind Load Doors

For use with 8' thru 16' Wide "SRP" and "Advantage" Wind Load Doors

This is a supplement to the standard **Steel Door Installation Instructions** (copy included), and contains important information for Wind Load doors. These doors include additional jamb brackets and struts, and require specific attachment methods for hinges, track and struts beyond what is required on standard doors. The identification, installation and attachment of these parts are outlined in these supplemental instructions.

The windload reinforcement on 8' and 9' doors is configured differently from that of 16' doors, as are the intermediate hinges. Wind Load doors not installed with the proper reinforcement (struts, hinges, jamb brackets, track, and fasteners) as detailed herein will not perform as designed and tested to withstand the wind load pressure.

The additional hardware, struts and other components required for proper installation of a General Doors Corp. Wind Load door beyond those of the standard Steel Door Installation Instructions are listed below in Figure #1, and have been included in the package. Please locate, identify and inventory these items to insure that proper installation can be completed as instructed.

(Figure #1)

Extra Parts for 8' & 9' Wide SRP & Advantage Wind Load Doors		
Description	4 Section High	5 Section High
2" HD STRUT	6	8
1/4-20 x 3/4 TEK SCREWS	36	46
PUSH RETAINER	10	12
5/16" X 1-5/8 TRACK LAGS	8	10
Extra Parts for 16' Wide SRP & Advantage Wind Load Doors		
Description	4 Section High	5 Section High
3" HD STRUT (Replaces 2 Standard Struts)	8	10
1/4-20 x 3/4 TEK SCREWS	106	130
PUSH RETAINER	10	12
# 1 HINGES	6	8
5/16" X 1-5/8 TRACK LAGS	8	10

For questions relating to components or difficulty with installation or instructions, contact:

General Doors Corporation
One Monroe Street (At Radcliffe)
P.O. Box 205
Bristol, PA 19007-0205
215-788-9277
fax 215-788-9450
www.general-doors.com

Overview

Struts are attached lengthwise across the door for added strength. Wind Load struts differ in the depth and thickness of the struts, and in their attachment method for a Wind Load certified door. Refer to Figures #2 thru #5 for your model and size door to determine the correct locations for placement of the struts itemized in Figure #1, and follow these instructions for their correct attachment.

The number, position and attachment methods of hinges are also different for Wind Load doors for added strength and resistance to the twisting associated with windload pressures. Refer to Figures #2 thru Figure #5 for your model and size door for the correct locations for placement of the additional hinges itemized in Figure #1, and follow these instructions for their correct attachment.

The correct vertical track has been included for your Wind Load door, however it is important that all supplied jamb brackets be properly and tightly fastened into the door frame structure and jamb with the fasteners provided to insure the door track attachment will resist the windload pressure. Refer to Figures #2 thru #5 for your model and size door for the correct attachment of the vertical track and use of the additional lag bolts itemized in Figure #1. Wind Load doors have more attachments than standard doors.

**** Important Note **** It is the responsibility of the professional of record for the building or structure to insure that the structural elements of the door frame and jamb are in compliance with the current building code, and constructed in a method and configuration sufficient to carry the transferred windload pressure.

The door models and sizes covered in these instructions have been tested according to the requirements of the IBC (International Building Code), and are certified to withstand the pressures associated with a 120MPH wind load. This is the maximum required by the IBC in all regions along the East Coast from Virginia and points north. North Carolina and points south, have some coastal areas with higher requirements. If your structure is located in those southern high wind zones, please contact General Doors. Additional reinforcement may (or may not) be required. (The 9 x 7 Advantage Door has actually tested to withstand 150 MPH when reinforced as described here.)

Installation Instructions

When attaching the bottom bracket to the end stiles of both the SRP and Advantage doors as in step #3 of the Steel Door Installation Instructions, the (2) Tek screws marked in Figure #6 are left out until the lower strut is installed.

(Figure #6) SRP & Adv.

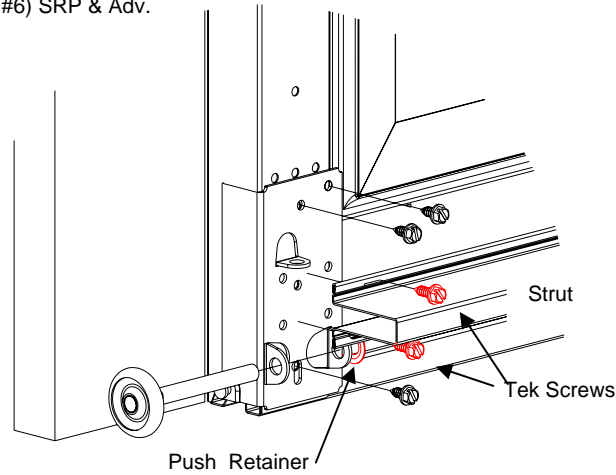

Install the appropriate strut across the bottom of the door by locating each end on the bottom brackets as shown in Figure #6. Secure in place with (2) self-drilling Tek screws. Secure the bottom strut to every intermediate stile as shown in Figure #7 for SRP doors or Figure #8 for Advantage doors with (2) self-drilling Tek screws.

(Figure #7) SRP

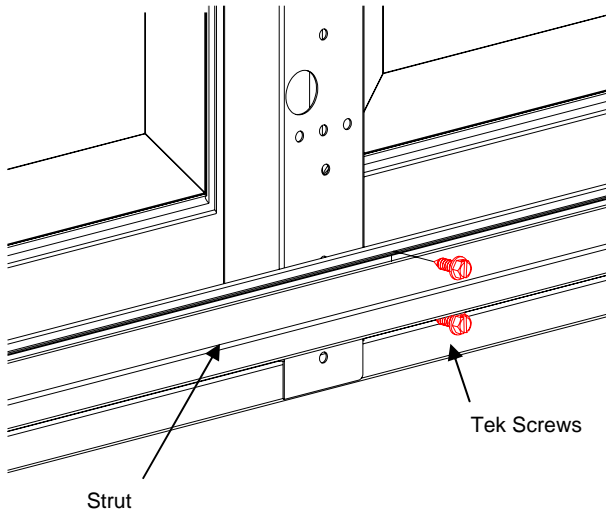

(Figure #8) Adv.

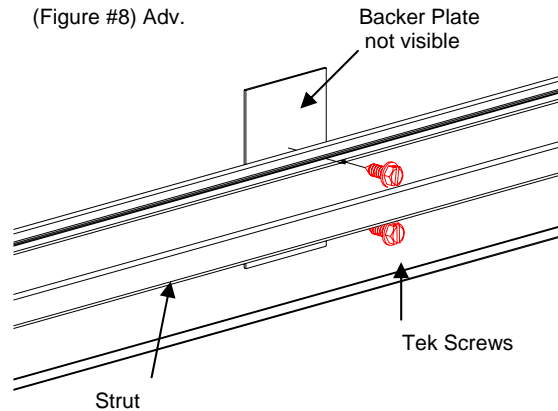

Fasten the #1 hinges to the end stiles at the top of the door section per Figure #9 for SRP doors and Figure #10 for Advantage doors. Use (2) screws through the hinge holes closest to the edge of the door section as shown to resist hinge twisting when the door is under windload pressure. Leave out the (2) screws for the strut (one at the bottom of the hinge) until the strut is installed.

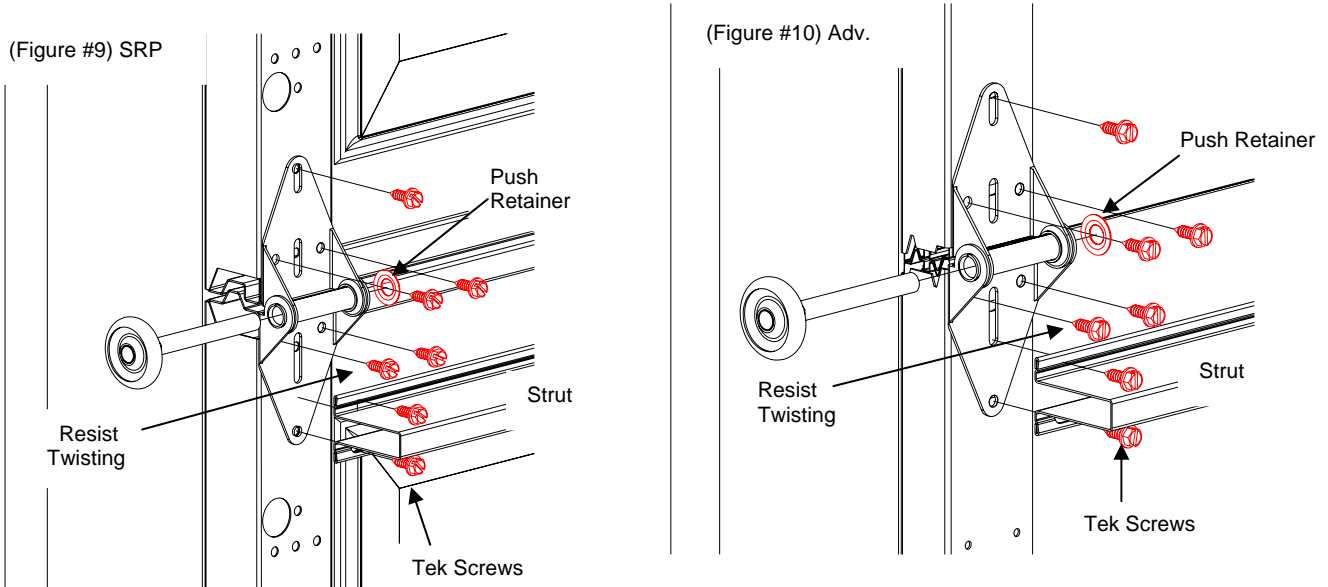

Fasten intermediate hinges in all locations across top of door section with a single screw, (See Figure #11 for SRP doors and Figure #12 for Advantage doors), but do not tighten until strut has been installed. All intermediate hinges are always marked #1. Refer to Figures #2 thru Figure #5 for your model and size door for the correct locations of the intermediate hinges.

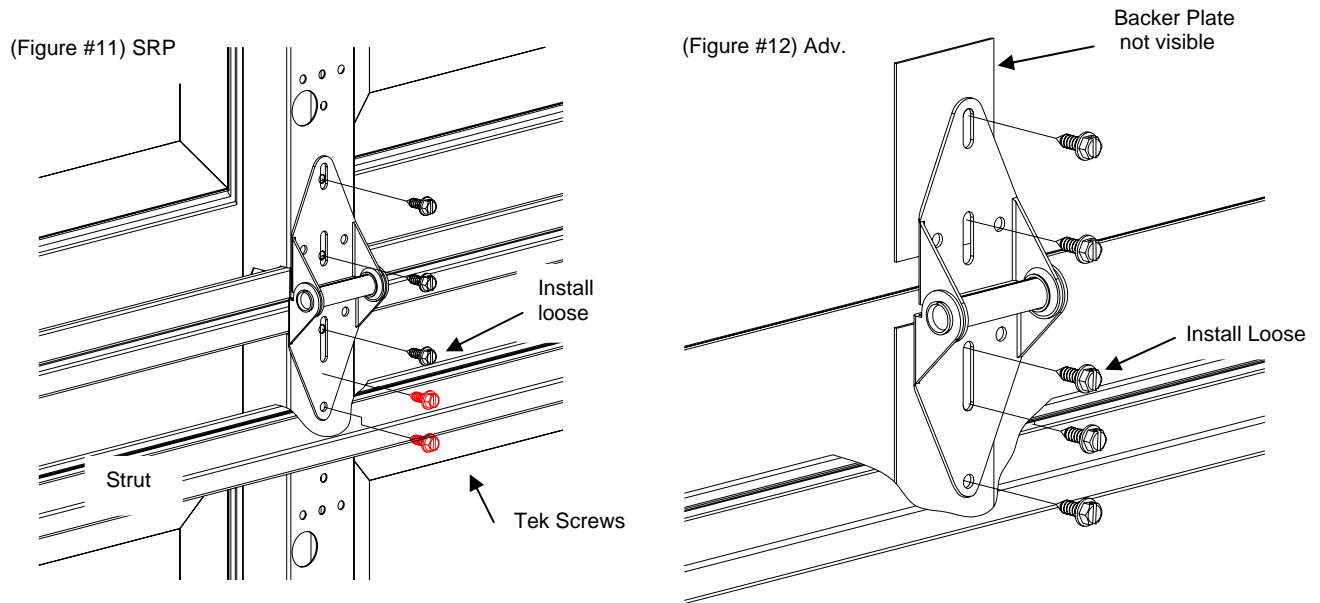

Install a strut across the top of the door section over the lower leaf of the hinges as shown in drawings above. Secure in place with the (2) self-drilling Tek screws. Secure the strut to all the intermediate hinges as shown in Figure #11 for SRP doors and Figure #12 for Advantage doors. Tighten all screws in place.

Install vertical track per step #6 of the Steel Door Installation Instructions. Make sure that lags have been installed in all of the jamb brackets. There are a total of (4) jamb brackets on each side (2), for a total of (8) jamb brackets that must be attached using 5/16" x 1-5/8" long lag screws. (See Figure #13).

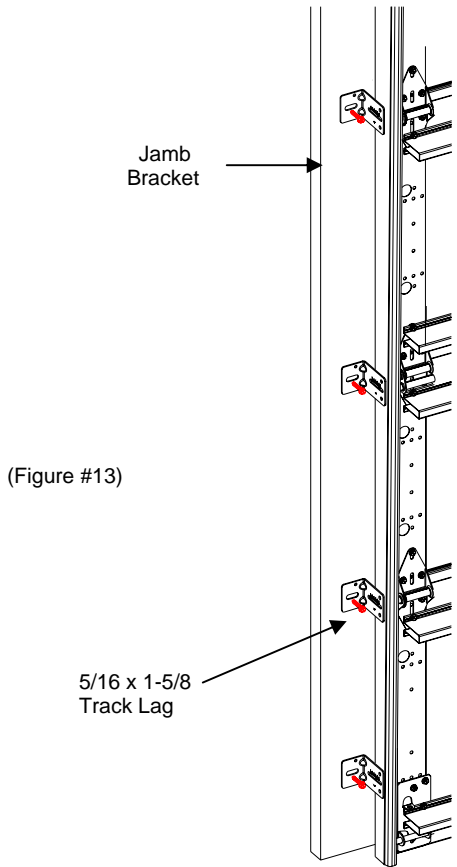

Fasten hinges across the top of the second section using #2 hinges on the end stiles. As on the bottom section, use (2) screws through the hinge holes closest to the edge of the door section on the end stiles and (1) screw for the intermediate hinges. See Figure #14 for SRP doors and Figure #15 for Advantage doors.

(Figure #14) SRP

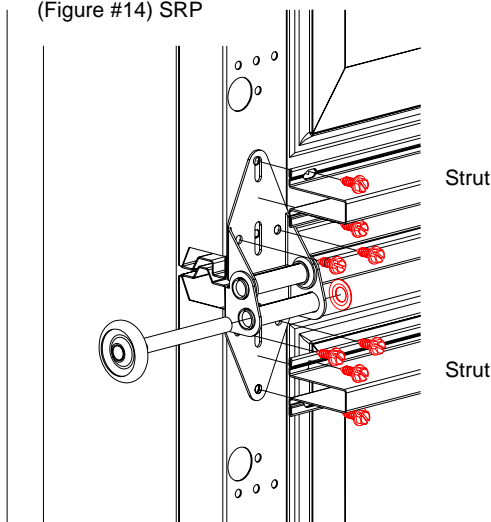

(Figure #15) Adv.

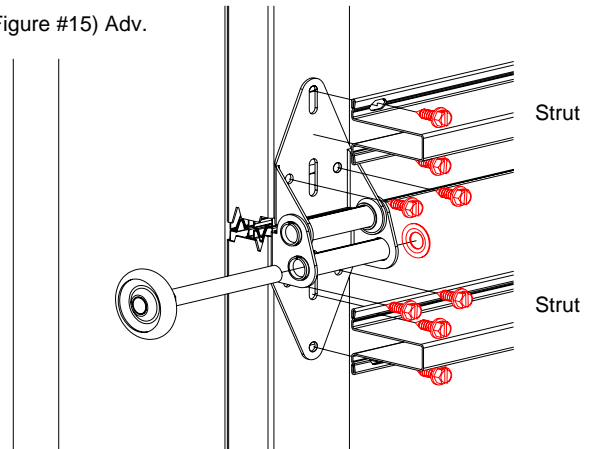

Install the supplied strut across the top of the door section as shown in Figure #14 for SRP doors and Figure #15 for Advantage doors. Fasten the strut to the intermediate hinges as shown in Figure #16 for SRP doors and Figure #17 for Advantage doors. Tighten all screws in place.

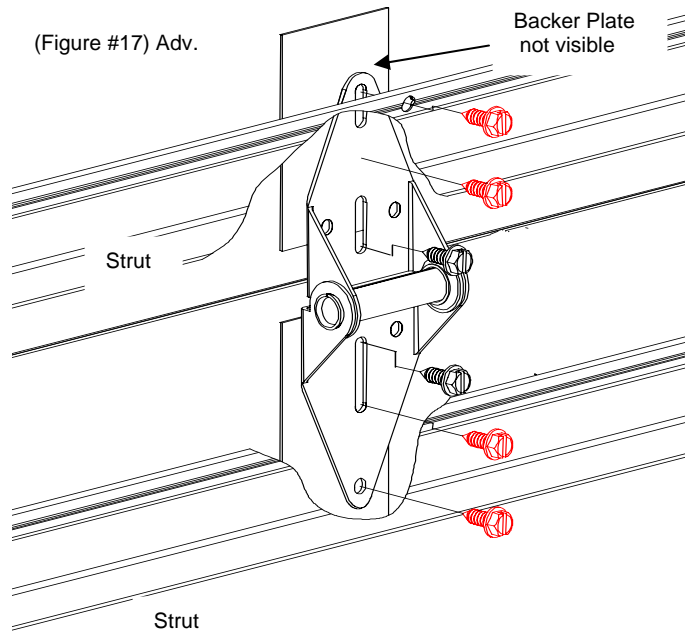
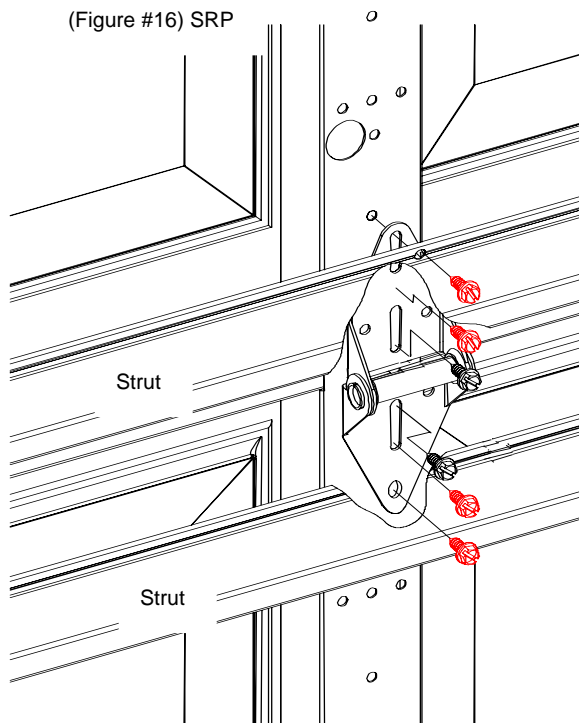

Install door section in track and align with lower section as per Step #8 of installation instructions. Install strut if required on upper leaf of hinges and fasten as depicted in Figure #16 for SRP doors or Figure #17 for Advantage doors.

Repeat the above steps for each additional door section. Continue with Step #10 of installation instructions. When assembling the top door section install the top roller carrier and strut as depicted in Figure #18. Be sure to fasten the strut to all of the intermediate stiles or hidden backer plates corresponding to locations that have intermediate hinges below, similar to Figure #7 for SRP doors and Figure #8 for Advantage doors. Install (2) remaining lags in each flag bracket on each side using 5/16" x 1-5/8" long lag screws. There should be a total of (4) lag screws per flag bracket.

(Figure #18)

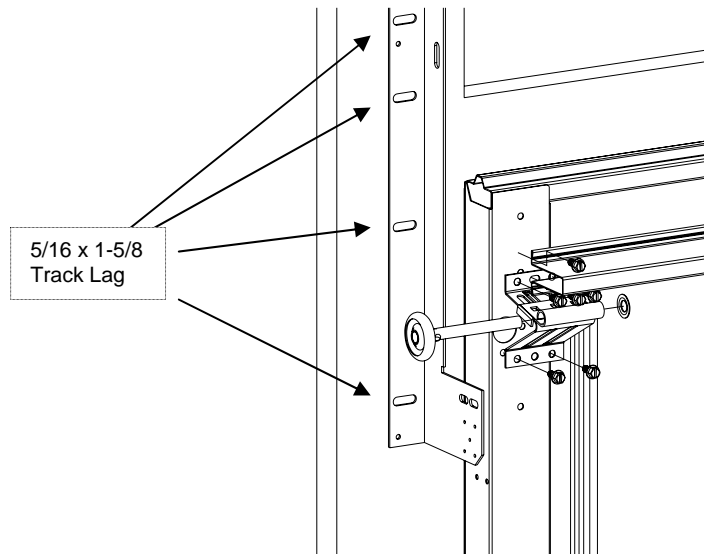

At completion insure that all screws, bolts, and lags are tight. **Double Check.** Install push retainers on shaft of each roller of door to prevent shaft from pulling out if door bows from windload pressure. Do not push retainer tight against hinge or bracket, but let 1/8 to 1/4 inch clearance for roller to float.